



_____	_____
_____	_____
_____	_____
_____	_____
_____	_____

2.1		.....	- 2 -
2.2		.....	- 2 -
2.3		.....	- 3 -
2.4		.....	- 3 -
3.1		.....	- 3 -
	3.1.1	.....	- 3 -
	3.1.2	.....	- 4 -
3.2		.....	- 4 -
3.3		.....	- 9 -
	3.3.1	.....	- 9 -
3.4		.....	- 10 -
3.5		.....	- 11 -
	3.5.2	.....	- 17 -
	3.5.3	.....	- 18 -
4.1	/	.....	- 18 -
	4.1.1	.....	- 18 -
	4.1.2	.....	- 20 -
	4.1.3	.....	- 22 -
	4.1.4	.....	- 22 -
4.2		.....	- 24 -
	4.2.1	.....	- 24 -
	4.2.2	.....	- 28 -
	4.2.3	.....	- 28 -
	4.2.4	.....	- 28 -
4.3	" "	.....	- 29 -
4.4		.....	- 31 -
5.1		.....	- 33 -
	5.1.1	.....	- 33 -
	5.1.2	.....	- 33 -
5.2		.....	- 34 -
6.1		.....	- 36 -
6.2		.....	- 37 -
6.3		.....	- 37 -
6.4		.....	- 38 -

7.1	.....	- 38 -
7.1.1	.....	- 38 -
7.1.2	.....	- 39 -
7.1.3	.....	- 39 -
7.1.4	.....	- 40 -
7.2	.....	- 42 -
8.1	.....	- 42 -
8.2	.....	- 44 -
8.3	.....	- 44 -
8.4	.....	- 47 -
8.5	.....	- 47 -
9.1	.....	- 47 -
9.2	.....	- 48 -
9.2.1	.....	- 48 -
9.2.2	.....	- 49 -
9.3	.....	- 60 -
10.1	.....	- 60 -
10.1.1	.....	- 60 -
10.1.2	.....	- 60 -
10.2	.....	- 61 -
10.3	.....	- 61 -
10.4	.....	- 64 -

" "

“ ”

1

2

3

4 1#

5

6

1

[2017]5

[2017-510132-38-03-117403-BQFG]0005 2017 2

10

2

[2017]22

2017 3 23

3

[2017]4

2017 3 3

4

[2017]10

2017 4 20

5

[2017]235

2019 9 20

6

7

8

9

10

11

12

13

14

15 NMP

16

17

18

19

20

21

22

10

23

24

103° 54 2                      30° 23 16

4

2017 9

"

"

"

"

"

"

63.8311

"

"

2

8

21

300000

1#

8

2#

12

2#

12

2017

[2017-510132-38-03-117403-BQFG]

0005

2017 8

2017 9 20

[2017]235

2017

7

2018 6

682

2017 4

400

8

300

2018 10 2019 3

2019 4 18

8

2019 7 26~29

1

2015 1 1

2

2018 1 1

3

2018

4

2018 12 29

5

58 2016 11 7

6

1998 11 29

253

2017 7 16

7

[2017]4 2017 11 20

8

[2008]70 2008 9 18

9

<

>

[2018]8 2018 1 3

成 市 新 能 源 有 限 公 司 离 子 电 池 制 造 项 目 竣 工 环 境 保 护 收 监 测 报 告



			3 15m <sup>3</sup>		
		4 PSA 960Nm <sup>3</sup> /h	2 PSA 440Nm <sup>3</sup> /h		/
		40 300m <sup>3</sup> /h 32 2m <sup>3</sup> 7 2m <sup>3</sup>	46 300m <sup>3</sup> /h 12 2m <sup>3</sup> 7 300m <sup>3</sup> /h 7 2m <sup>3</sup>		/
		15F 16000m <sup>2</sup> 5F 3000m <sup>2</sup>	5F 2F		
		1 3F 10095m <sup>2</sup>	1#		
		1# 2# 6000m <sup>2</sup>	2#		/
		1# 2# 3000m <sup>2</sup>	2#		
		1F 740m <sup>2</sup>			
		7 100m <sup>3</sup> NMP 3 NMP NMP	4		/
		4 12 NMP 12 20m	2# 1# 3 4 4 NMP 4 25m NMP 24		/
		100m <sup>3</sup>	50m <sup>3</sup> 8m <sup>3</sup> /d		/

		2m <sup>3</sup> /d			
		4m <sup>3</sup> /d			
		2 160m <sup>3</sup> /d	20		
		1 170m <sup>3</sup>	141m <sup>3</sup> /d		
		1 300m <sup>2</sup>	309m <sup>2</sup>	/	
		1 300m <sup>2</sup>	1200m <sup>2</sup> 309m <sup>2</sup>	/	

1#		79488m <sup>2</sup> 1F			
		740m <sup>2</sup> 1F			
		309m <sup>2</sup> 1F			
		512m <sup>3</sup> /h	412m <sup>3</sup> /h	100m <sup>3</sup> /h	
		5F 2F			
	[2017]5	141m <sup>3</sup>	62m <sup>3</sup>	57m <sup>3</sup>	70m <sup>3</sup> 9m <sup>3</sup> 62m <sup>3</sup> 57m <sup>3</sup>
	[2017]188	1200m <sup>2</sup> 309m <sup>2</sup>			

	[2017]32	80t/h	68t/h	33t/h	

1	" + + "	" + + +	" + + "	GB30484-2013	GB30484-2013
2	" + "	" + "	" + "	NMP 20m	NMP 25m GB30484
3					GB12348-2008 3

4

NMP

1#

5

NMP

" 2.0mmHDPE +  
+ "

" "

$1 \times 10^{-10} \text{cm/s}$

\$1

3			3	3
4			8	8 8
5			8	8 4
6			8	8
7			8	8
8	MES	MES	1	1
9			8	8 8 8
10			60	64 32
11			32	32
12			48	48 24
13		AGV	1	8
14			1	8
15		JR	8	8 4
16			8	8 4
17			4	4
18			7	8
19			1	1 8 8 8
20	+PACK		4	2 2 2
21			8	6
22		+	46	46
			7	7
23		PSA	2	2
24			1	1
25			2	2
26		+	1	2
27			1	1
28			12	12
29			1	1
30			1	1

N-

NMP

3.3-1

1

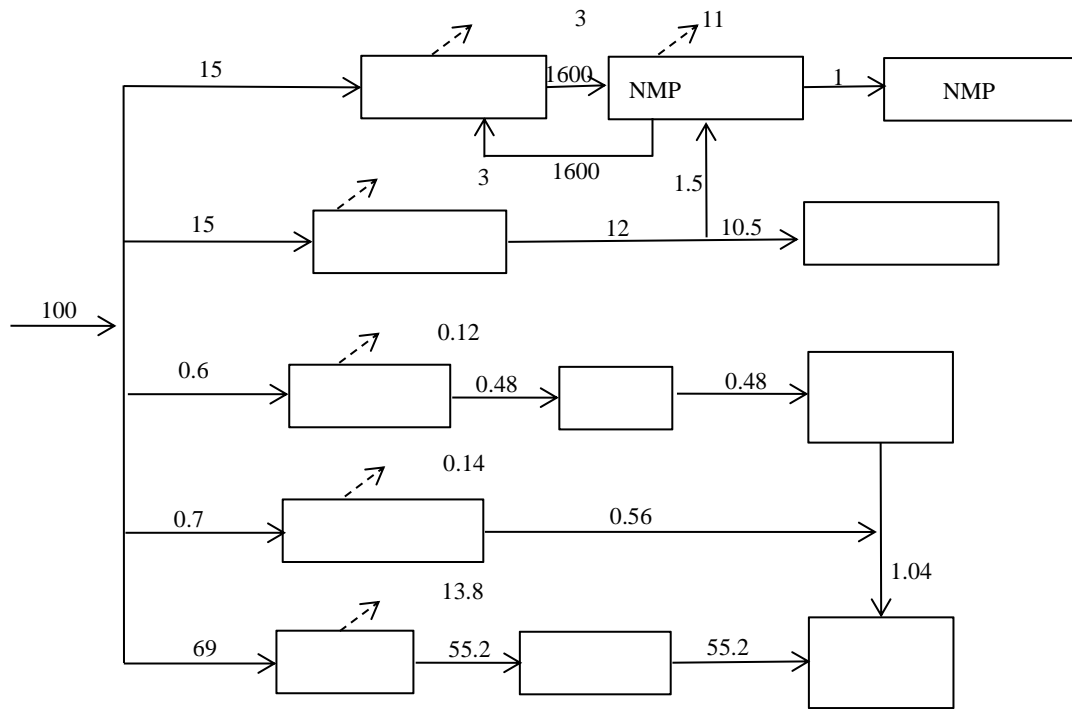

PVDF

NMP

IQC

200kg

NMP

100m<sup>3</sup>

100

成 市 新 能 源 有 限 公 司 离 子 电 池 制 造 目 竣 工 环 境 保 护 收 监 测 报 告



100~102

15h

12

2.5V-3.8V

5

200

70-90

45

PACK

PACK



/

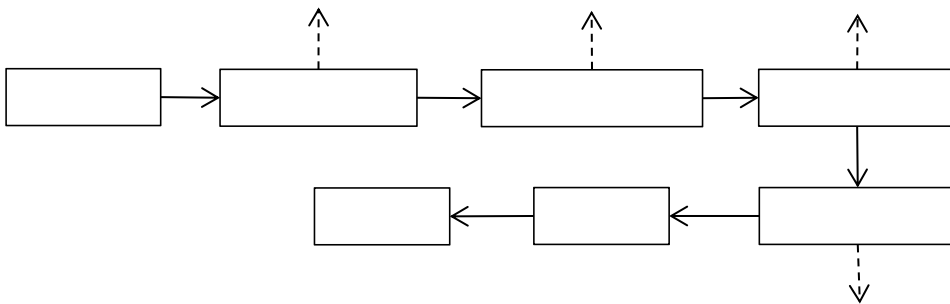

+

NMP

NMP

1#

	NMP	NMP	3
4	NMP	100m <sup>3</sup>	
	NMP		

a

b

pH

c

+

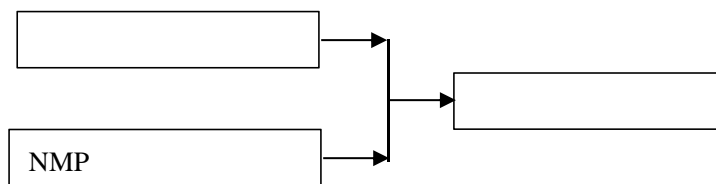
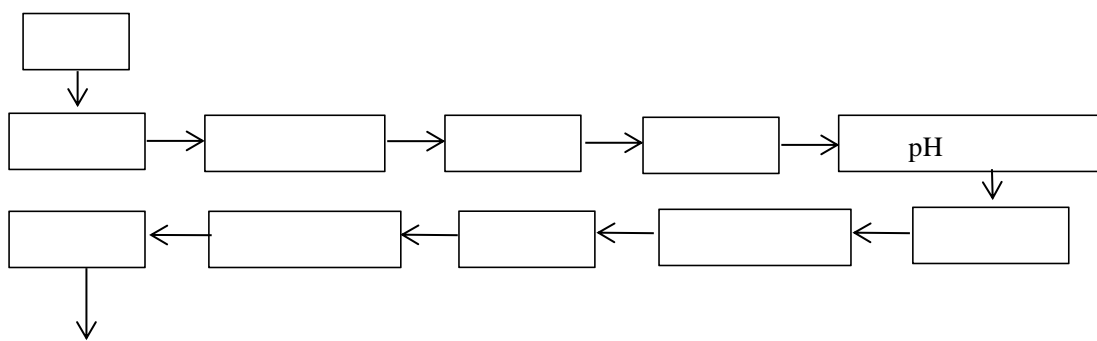

NMP

1#

1 NMP

1#

4

NMP

NMP

1 NMP

25m

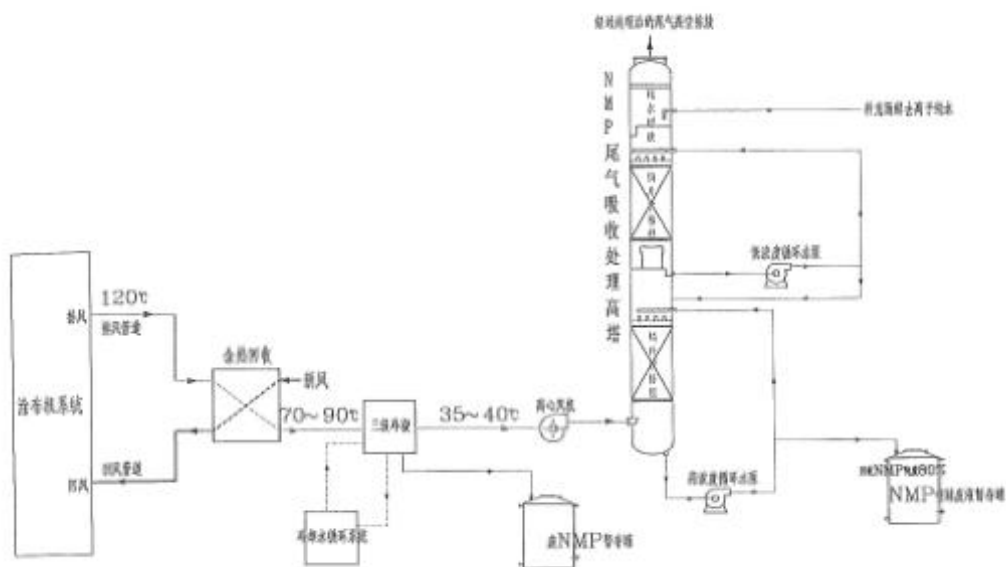

2

2

1

24

2 NMP

1 NMP

7 100m<sup>3</sup>

3

4

NMP

NMP

3

3

2

1

		NMP	VOCs	4 NMP + + +4 25m
				+
		NMP	VOCs	/

4.1-3

1#		70		
		70		
		75		
		80		
		70		
		70		
		70		
		85		
		90		
		90		
		85		
		85		

NMP

NMP

NMP

NMP

" HDPE + "

$1.0 \times 10^{-10} \text{cm/s}$

4.1-4

1			
2	NMP NMP NMP		
3			
4			

5			
6			
7			
8			
9			
10			
11			
12			
13			

1

2

GB50016-2014

1#

1

2

a

b

c

NMP

d

NMP

e

f

g

3

a

b

4

" "

1

"

"

2

3

4

1

1 1

2

3 1 400m<sup>3</sup>

4 PE

5

6

7

2

a NMP

NMP 7 NMP 3 NMP 4 NMP

100m<sup>3</sup> 1.2m

1m<sup>3</sup>

b

57m<sup>3</sup>/d 1

400m<sup>3</sup> 277m<sup>3</sup>/d

1

10m<sup>3</sup>

c

1

2

3

30

4

COD<sub>Cr</sub>

" "

4.2-1

NMP	NMP 1.2m 1m <sup>3</sup>	NM " 2.0mmHDPE + "
	/ 1m <sup>3</sup>	
	1 1.0×10 <sup>-10</sup> cm/s +HDPE 2mm	
	2 C30S8 1 3mm	

	5cm C20	1 3mm	
3		PVC	$1 \times 10^{-10} \text{cm/s}$

" "

8300

30

2.77%

" "

4.3-1

			NMP +20m	22800	4 NMP 25m	8000
				10	3                      2 1	8
			24	15		10
		SS COD BOD5 NH3-N	2 30m <sup>3</sup> 2                      160m <sup>3</sup>	/	20 141m <sup>3</sup> /d	/
		SS COD BOD5 NH3-N	2m <sup>3</sup> /d	18	1                      50m <sup>3</sup>	3
			4m <sup>3</sup> /d	25	8m <sup>3</sup> /d	25
	/	L <sub>Aeq</sub>		100		100
				10	309.35m <sup>2</sup>	2
				5	1200m <sup>2</sup>	0
				/		/
			+ 1 10 <sup>-10</sup> cm/s	/	+ " 2.0mmHDPE + " 1 10 <sup>-10</sup> cm/s	/
			100m <sup>3</sup> 1 10 <sup>-10</sup> cm/s	30		0
			135000m <sup>2</sup>	/		/
		NMP NMP	1.2m 1m <sup>3</sup>	/		/
			1m <sup>3</sup>	/		/
			170m <sup>3</sup>	15		0
				150		150
				20		
				23228	/	8300

8

2#

9

15F  
16000m<sup>2</sup>

		3	2 1
	100m <sup>3</sup>  + +  2m <sup>3</sup> /d  4m <sup>3</sup> /d	8m <sup>3</sup> /d  + + + +	
	2  160m <sup>3</sup> /d	20  141m <sup>3</sup> /d	57m <sup>3</sup>  70m <sup>3</sup>
	1  300m <sup>2</sup>		309m <sup>2</sup>
	1  300m <sup>2</sup>		1200m <sup>2</sup> 309m <sup>2</sup>
	170m <sup>3</sup>		/
	NMP 1.2m  1m <sup>3</sup>		
	1m <sup>3</sup>		
	60	64  32	4

		7	8	1
+PACK	4	2 2	2	
	8		6	

"

"

" "

1 " "

2

3

4

5

[2017] 12

[2017] 221

		638311		23228	
		1#		8	
2#		8			
					5m <sup>3</sup> /n
	PSA	4		960Nm <sup>3</sup> /h	
			66m <sup>3</sup> /h 0.7MPa		
				15F	16000m <sup>2</sup> 5F
		14000m <sup>2</sup>	3F		10095m <sup>2</sup>
				7	100m <sup>3</sup> NMP
		1F	740m <sup>2</sup>		
	6000m <sup>2</sup>	3000m <sup>2</sup>			
				4	NMP 12
				100m <sup>3</sup>	1
	2m <sup>3</sup> /d	1	4m <sup>3</sup> /d	1	170m <sup>3</sup>
		1	300m <sup>3</sup>	1	300m <sup>3</sup>
		2	160m <sup>3</sup> /d		
300m <sup>2</sup>					
					21

" + + " + + + "

GB30484- -2013

" +

"

NMP NMP

" + " NMP

20m

NMP

NMP

“ ”

GB8978-1996

GB/T31962-2015 1 B

13	GB30484-20	6~9	150	300	140 30
	GB8978-1996	2.0	40	20	0.1 5.0
	GB30484-2013			/	/
	GB8978-1996	0.1	5.0	/	/
GB8978-1996	GB/T31962-2015	6~9	500	300	400 45
					/
		8	70	100	20

GB30484-2013 5 6

GB14554-93 1 2

		30	mg/m <sup>3</sup>	GB30484-2013 5 6
		0.3	mg/m <sup>3</sup>	
		50	mg/m <sup>3</sup>	
		2.0	mg/m <sup>3</sup>	
		20	mg/m <sup>3</sup>	GB14554-93 1 2

GB12348-2008 3

		97.351	/
		15.76	/
		1.02	/
		2.79 10 <sup>-5</sup>	/
		1.86 10 <sup>-5</sup>	/
		1.86 10 <sup>-6</sup>	/

1#		pH	2 4
2#		pH	
3#		pH	

□

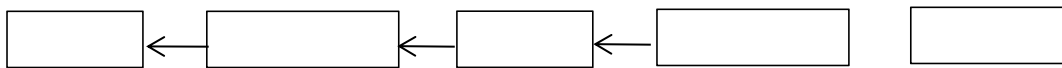





1			VOCs	4	2 3

NMP

10  
4

VOCs



NMP

NMP

NMP

NMP

" HDPE + " 1.0

× 10<sup>-10</sup>cm/s

7.1-5

1			
2	NMP NMP NMP		
3			
4			
5			
6			
7			
8			
9			
10			
11			
12			

13			
----	--	--	--

250m

1

6	1	A Leq[dB A ]	2
6			2
			4

5





	190626Y-15-01W-4		134	135	0.4	/	/	
	190626W-09-01W-1		28	27	1.8	/	/	
	190626Y-15-03W-4		63	61	1.6	/	/	
	190627Y-15-03W-4		63	67	3.1	/	/	
	190627Y-15-02W-4		3	35	2.9	/	/	
	190626Y-15-01W-1		4.63	4.88	2.6	/	/	
	190626Y-15-01W-1		/	/	/	95.9	/	
	190626Y-15-02W-1		5.45	5.20	2.2	/	/	
	190626Y-15-02W-1		/	/	/	98.6	/	
	190627Y-15-02W-1		4.34	4.16	2.1	/	/	
	190627Y-15-02W-1		/	/	/	95.9	/	
	190626Y-15-01W-4		7.69	8.47	4.8	/	/	
	190626Y-15-01W-4		/	/	/	96.1	/	
	190626Y-15-03W-4		11.5	11.5	0.0	/	/	
	190626Y-15-03W-4		/	/	/	96.1	/	
	190627Y-15-02W-3		6.30	6.54	1.9	/	/	
	190627Y-15-02W-3		/	/	/	96.1	/	
	190627Y-15-03W-4		21.4	22.0	1.4	/	/	
	190627Y-15-03W-4		/	/	/	96.1	/	
	190626Y-15-01W-4		5.79	5.83	0.3	/	/	
	190626Y-15-01W-4		/	/	/	103	/	
	190626W-07-27W-1		0.19	0.20	2.6	/	/	

	190626W-07-27W-1		/	/	/	98.0	/	
	190627Y-15-02W-4		0.10	0.11	4.8	/	/	
	190627Y-15-02W-4		/	/	/	98.0	/	
	190627W-10-01W-1		0.32	0.31	1.6	/	/	
	190627W-10-01W-1		/	/	/	99.7	/	
	190626Y-15-01W-4		161	148	4.2	/	/	
	190626Y-15-03W-4		35.7	38.2	3.4	/	/	
	190627Y-15-01W-4		146	139	2.1	/	/	
	190627Y-15-02W-4		6.84	7.58	5.1	/	/	
	190627Y-15-03W-4		19.4	20.6	3.0	/	/	
	190626W-31-01W-1		0.772	0.821	3.1	/	/	
	190626W-31-01W-1		/	/	/	97.7	/	
	190627Y-15-03W-4		0.160	0.163	0.9	/	/	
	190627Y-15-03W-4		/	/	/	95.3	/	
	190626Y-15-01W-4		0.01	0.01	0.0	/	/	
	190626Y-15-03W-4		0.21	0.21	0.0	/	/	
	190627Y-15-02W-4		0.47	0.47	0.0	/	/	
	190626Y-15-01W-4		/	/	/	94.6	/	
	190626Y-15-03W-4		/	/	/	99.0	/	
	190627Y-15-02W-4		0.0158	0.016	3.2	/	/	
	190627Y-15-02W-4		/	/	/	96.8	/	

1

2

3

			mg/m <sup>3</sup>	mg/m <sup>3</sup>		
VOCs	190627Y-15-01G-4		0.92	0.95	1.6	
	190627Y-15-03G-4		1.26	1.36	3.8	
	190626Y-15-01G-4		1.43	1.44	0.3	
	190626Y-15-03G-4		0.75	0.68	4.9	
VOCs	190627Y-15-01P-4		3.25	2.90	5.7	
	190627Y-15-03P-4		3.11	3.10	0.2	
	190626Y-15-01P-3		3.04	2.93	1.8	
	190626Y-15-03P-3		2.69	2.67	0.4	

2019	6	26	400	/d	400	/d
2019	6	27	400	/d	400	/d
					400	/d
						100%
						100%

				%	
2019	6	26		31.65t/d	
				31.65t/d	100%
				0.59t/d	100%
			N-	21.49t/d	100%
			16.94t/d	100%	
2019	6	27		31.65t/d	
				31.65t/d	100%

		0.59t/d	0.59t/d	100%
	N-	21.49t/d	21.49t/d	100%
		16.94t/d	16.94t/d	100%

	mg/L	mg/L	mg/L	mg/L	mg/L
	85.55%	97.0%	98.65%	84.9%	80.3%

GB30484-2013 5

GB12348-2008 3

" HDPE + "  $1.0 \times 10^{-10} \text{cm/s}$

		pH	mg/L	mg/L	mg/L	mg/L	mg/L	mg/L	mg/L	mg/L	mg/L	mg/L
	1	7.29	62	158	6.13	146	4.76	1.08	8.82			0.01
	2	7.27	58	145	6.08	140	4.32	0.96	9.32			0.01
	3	7.26	70	147	5.91	138	4.44	0.95	8.19			0.01
	4	7.25	66	154	5.81	134	4.59	0.89	8.08			0.01
		7.25-7.29	64	151	5.98	140	4.53	0.97	8.60			0.01
		6-9	50	300	2.0	70	30	20	70	/	0.1	5.0
	1	7.24	9	4.5	0.08	21	5.33	0.30	9.05			0.47
	2	7.25	9	4.1	0.07	21	5.52	0.19	9.81			0.47
	3	7.27	8	4.3	0.08	20	5.62	0.19	10.2			0.46
	4	7.23	10	4.6	0.09	21	5.40	0.15	9.84			0.47
		7.23-7.27	9	4.4	0.08	21	5.47	0.21	9.72			0.47
		6-9	50	300	2.0	70	30	20	70	/	0.1	5.0
		/	85.9	97.1	98.7	85	/	78.4	/	/	/	/
		pH	mg/L	mg/L	mg/L	mg/L	mg/L	mg/L	mg/L	mg/L	/	/
	1	7.73	10	38.7	1.33	73	9.59	0.55	11.7	0.426	/	/
	2	7.75	9	33.7	1.41	65	9.27	0.57	13.0	0.416	/	/
	3	7.79	8	36.3	1.42	69	9.37	0.59	13.7	0.384	/	/
	4	7.75	10	37.0	1.37	62	9.66	0.55	11.5	0.391	/	/

		7.73-7.79	9	36.4	1.38	67	9.47	0.56	12.5	0.404	/	/
		6-9	50	/	8	70	45	/	70			

		pH	mg/L	mg/L	mg/L	mg/L	mg/L	mg/L	mg/L	mg/L	mg/L	mg/L
	1	7.26	61	142	5.88	142	4.90	1.16	7.92			0.08
	2	7.29	52	145	5.66	131	5.10	1.18	9.13			0.04
	3	7.23	73	146	5.54	137	5.18	1.17	8.36			0.02
	4	7.29	59	142	5.79	140	4.78	1.20	9.01			0.01
		7.23-7.29	61	144	5.72	138	4.99	1.18	8.60			0.04
		6-9	50	300	2.0	70	30	20	70	/	0.1	5.0
	1	7.24	9	4.5	0.08	21	5.33	0.30	9.05			0.47
	2	7.25	9	4.1	0.07	21	5.52	0.19	9.81			0.47
	3	7.27	8	4.3	0.08	20	5.62	0.19	10.2			0.46
	4	7.23	10	4.6	0.09	21	5.40	0.15	9.84			0.47
		7.23-7.27	9	4.4	0.08	21	5.47	0.21	9.72			0.47
		6-9	50	300	2.0	70	30	20	70	/	0.1	5.0
		/	85.2	96.9	98.6	84.8	/	82.2	/	/	/	/
		pH	mg/L	mg/L	mg/L	mg/L	mg/L	mg/L	mg/L	mg/L	/	/
	1	7.66	28	20.2	1.19	67	12.3	0.86	20.9	0.184	/	/
	2	7.82	30	18.2	1.24	74	11.6	0.81	22.4	0.170	/	/
	3	7.54	23	20.5	1.51	80	12.6	0.80	22.9	0.158	/	/
	4	7.68	28	20.0	1.53	65	12.4	0.82	21.7	0.162	/	/

		7.54-7.82	27	19.7	1.37	72	12.2	0.82	22.0	0.168	/	/
		6-9	50	/	8	70	45	/	70			

12

60

2000

312m<sup>3</sup>/a

0.052m<sup>3</sup>/

GB/T31962-2015 1 B

pH

GB8978-1996 4

pH

GB30484-2013 2

GB30484-2013 2

06 26	001	1#	VOCs		m <sup>3</sup> /h	20184	21226	21664	21025	\	\
				mg/m <sup>3</sup>	mg/m <sup>3</sup>	3.10	3.01	2.98	3.03	50	
					kg/h	0.0626	0.0639	0.0646	0.0637	\	\
06 27		VOCs		m <sup>3</sup> /h	19903	19902	19667	19824	\	\	
			mg/m <sup>3</sup>	mg/m <sup>3</sup>	4.01	2.94	3.08	3.34	50		
				kg/h	0.0798	0.0585	0.0606	0.0663	\	\	
06 26	002	2#	VOCs		m <sup>3</sup> /h	22081	22523	22993	22532	\	\
				mg/m <sup>3</sup>	mg/m <sup>3</sup>	3.34	3.02	2.94	3.10	50	
					kg/h	0.0738	0.0680	0.0676	0.0698	\	\
06 27		VOCs		m <sup>3</sup> /h	22040	21979	21338	21786	\	\	
			mg/m <sup>3</sup>	mg/m <sup>3</sup>	3.81	2.94	3.51	3.42	50		
				kg/h	0.0840	0.0646	0.0749	0.0745	\	\	
06 26	003	3#	VOCs		m <sup>3</sup> /h	21441	21209	21692	21447	\	\
				mg/m <sup>3</sup>	mg/m <sup>3</sup>	2.67	2.92	3.42	3.00	50	
					kg/h	0.0572	0.0619	0.0742	0.0644	\	\
06 27		VOCs		m <sup>3</sup> /h	21748	21288	21656	21564	\	\	
			mg/m <sup>3</sup>	mg/m <sup>3</sup>	3.43	2.98	3.10	3.17	\	\	
				mg/m <sup>3</sup>	3.43	2.98	3.10	3.17	50		
			kg/h	0.0746	0.0634	0.0671	0.0684	\	\		

06 26	004	4#	VOCs		m <sup>3</sup> /h	22268	19025	21739	21011	\	\
					mg/m <sup>3</sup>	2.27	2.08	2.68	2.34	50	
					kg/h	0.0505	0.0396	0.0583	0.0495	\	\
06 27		4#	VOCs		m <sup>3</sup> /h	22175	21853	21942	21990	\	\
					mg/m <sup>3</sup>	3.70	3.21	2.96	3.29	50	
					kg/h	0.0820	0.0701	0.0649	0.0723	\	\

GB30484-2013 5

9-1

9.2-1

mg/m <sup>3</sup>	06 26		0.64	1.58	1.82	1.44	1.86	2.0	
			1.84	1.81	0.68	0.70			
			1.78	1.16	1.73	0.72			
			1.79	1.86	1.21	1.74			
			0.58	1.70	0.70	1.80			
mg/m <sup>3</sup>	06 27		0.62	0.82	0.70	0.94	1.71	2.0	
			0.69	0.99	0.82	0.76			
			1.60	1.18	1.60	1.31			
			1.71	0.91	1.24	1.67			
			1.16	1.17	1.38	1.14			
mg/m <sup>3</sup>	06 26		0.200	0.217	0.200	0.184	0.251	0.3	
			0.200	0.217	0.234	0.217			
			0.200	0.234	0.200	0.184			
			0.217	0.200	0.243	0.217			
			0.251	0.267	0.200	0.251			

mg/m <sup>3</sup>	06 27		0.200	0.200	0.184	0.167	0.217	0.3	
			0.200	0.200	0.217	0.217			
			0.167	0.167	0.200	0.167			
			0.200	0.200	0.217	0.200			
			0.184	0.217	0.184	0.184			

GB30484-2013 6

GB30484-2013 6

	2019 06 26		10	10
			10	
			10	
			10	
	2019 06 27		10	10
			10	
			10	
			10	
/	/		20	
/	/			

GB14554-93 1

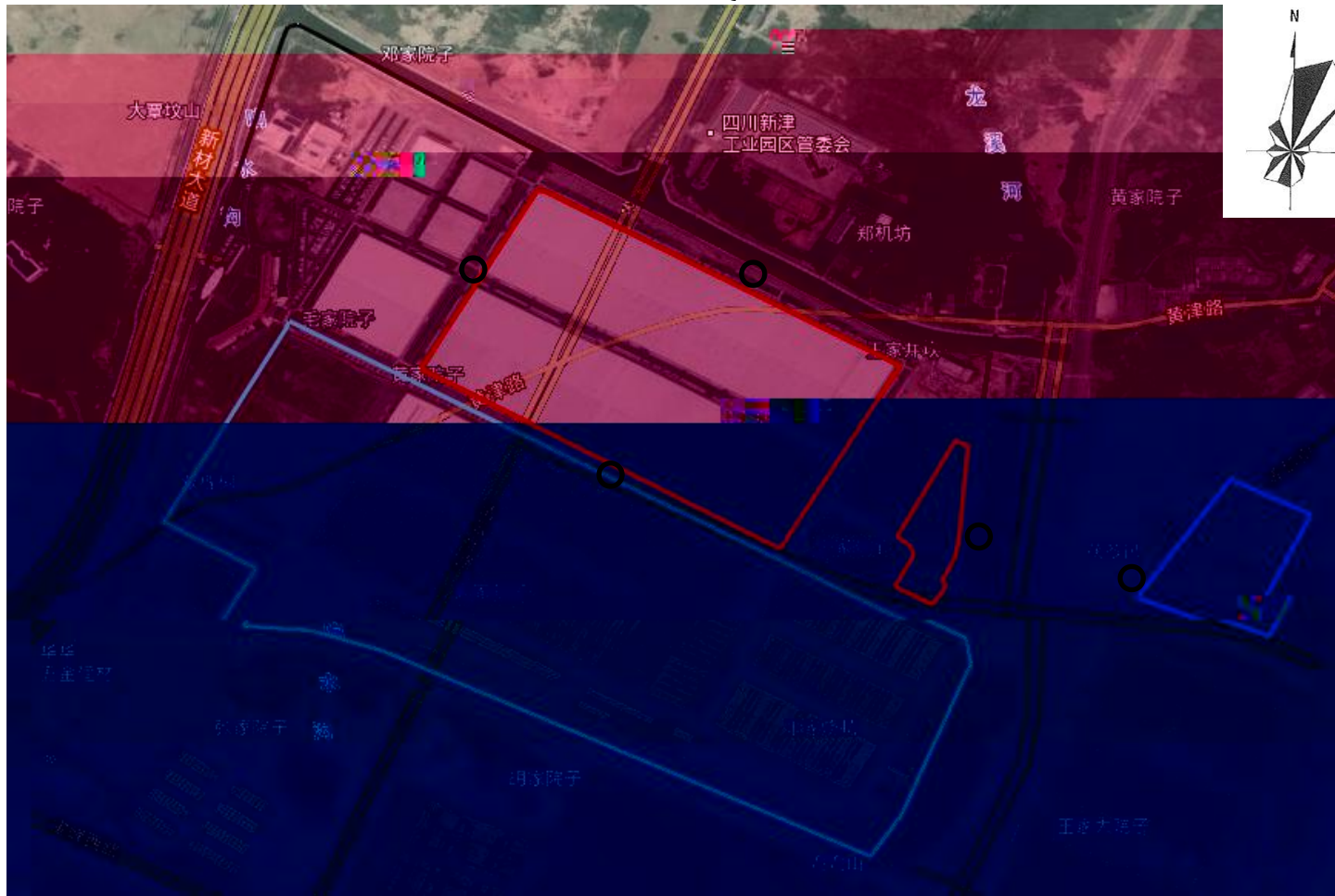

06 26	1#	10:31~10:33	56	65		22:26~22:28	49	55	
		13:49~13:51	57	65		01:38 ~01:40	42	55	
	2#	10:41~10:43	51	65		22:36~22:38	42	55	
		13:57~13:59	50	65		01:46 ~01:48	41	55	
	3#	10:51~10:53	51	65		22:45~22:47	42	55	
		14:05~14:07	50	65		01:56 ~01:58	42	55	
	4#	10:59~11:01	46	65		23:04~23:06	41	55	
		14:13~14:15	48	65		02:09 ~02:11	42	55	
	5#	11:13~11:15	51	65		23:12~23:04	42	55	
		14:22~14:26	52	65		02:20 ~02:22	40	55	
	6#	11:28~11:38	51	65		23:22~22:32	44	55	
		14:33~14:43	49	65		02:38 ~02:48	44	55	
06 27	1#	09:47~10:49	57	65		22:04~22:06	47	55	
		14:03~14:05	57	65		23:06~23:08	46	55	
	2#	09:57~10:59	49	65		22:14~22:16	41	55	

成 市 新 能 源 有 限 公 司 离 子 电 池 制 造 项 目 竣 工 环 境 保 护 收 监 测 报 告

		14:14~14:16	50	65		23:13~23:15	41	55	
3#		10:08~10:10	52	65		22:22~22:24	42	55	
		14:23~14:25	50	65		23:21~23:23	42	55	
4#		10:17~10:19	47	65		22:28~22:30	40	55	
		14:34~14:36	48	65		23:33~23:35	41	55	
5#		10:31~10:33	53	65		22:38~22:40	42	55	
		14:41~14:43	51	65		23:41~23:43	43	55	
6#		10:47~10:57	51	65		22:43~22:53	45	55	
		14:52~15:02	51	65		23:55~24:05	44	55	

NMP

NMP

NMP

NMP

$\times 10^{-10}\text{cm/s}$

" HDPE + "

1.0

9.2-4

		97.351	-	1.904	1.904
		15.76	-	$8.58 \times 10^{-3}$	$8.58 \times 10^{-3}$
		1.02	-	$1.54 \times 10^{-3}$	$1.54 \times 10^{-3}$
		$2.79 \times 10^{-5}$	-	$2.65 \times 10^{-5}$	$2.65 \times 10^{-5}$
		$1.86 \times 10^{-5}$	-	-	-
		$1.86 \times 10^{-6}$	-	-	-

	mg/L	mg/L	mg/L	mg/L	mg/L
	85.55%	97.0%	98.65%	84.9%	80.3%

1

GB/T31962-2015 1

B pH

GB8978-1996 4 pH

GB30484-2013 2

GB30484-2013 2

2

1

GB30484-2013	5		
2			
	GB30484-2013	6	
			GB30484-2013
6			
3			
	GB12348-2008	3	
			GB12348-2008
4			
5			
	100%		1.904t/a
	0.00858	0.00154t/a	$2.65 \times 10^{-5}t/a$
			50
50			
			100%
	10.3-1	10.3-2	

项目公众意见调查名单

序号	姓名	年龄	性别	职业	学历	工作单位/住址	电话
1	孙静	27	女	工程师	硕士	宝峰雅庭	18335166265
2	王丽	28	女	工艺	本科	宝峰雅庭	13540973777
3	周梅	29	女	工程师	硕士	宝峰雅庭	17721960124
4	王莎	26	女	文员	大专	新津金华镇	13699463035
5	李亚	27	女	工人	中专	普兴火车站小区	18227684150
6	张茂玲	26	女	超市	中专	新津金华镇	15627411856
7	张凤	27	女	超市	中专	新津金华镇	13185675421
8	刘小梅	33	女	文员	初中	普兴骑龙村	15881113325
9	杨燊	27	男	职能	本科	普兴火车站	13679057149
10	向斌	29	男	销售经理	本科	普兴火车站	18011575230
11	张亚	25	女	营业员	专科	中国移动	13609070866
12	王正伟	40	男	土建工人	高中	火车站小区	13880871626
13	黎舒宁	28	女	会计	本科	普兴火车站	13782581635
14	陈霜	23	女	出纳	本科	普兴火车站小区	18328522717
15	何汶怡	25	女	护士	本科	普兴火车站小区	15282136762
16	邓欣	25	女	文员	大专	成都	15882314336
17	王亚	30	男	经理	本科	恒大	13709048566
18	梁朝杰	27	男	工人	专科	普兴火车站小区	18181507523
19	胡帅	26	男	个体	专科	新津普兴	13568207351
20	钟建华	32	男	IT	专科	新津金华镇	18081896758

32	王志鹏	34	男	工人	高中	火车站小区	15833038862
33	刘杰	45	男	工人	初中	火车站小区	17761213407
34	樊璠	28	女	无业	大专	新津县火车站小区	13960703736
35	唐铭	30	男	务工	大专	火车站小区	13628314969
36	何媛	34	女	工作人员	本科	火车站小区	15928134435
37	黄开凤	32	女	销售	大专	新津县金华镇	18030505190



1		50	100
		/	/
		/	/
2		50	100
		/	/
		/	/
3		50	100
		/	/
		/	/
4		50	100
		/	/
		/	/
5		50	100
		/	/
		/	/
6		/	/
		50	100
7		45	90

			5	10
			/	/
8				

" " 30

8300

" "





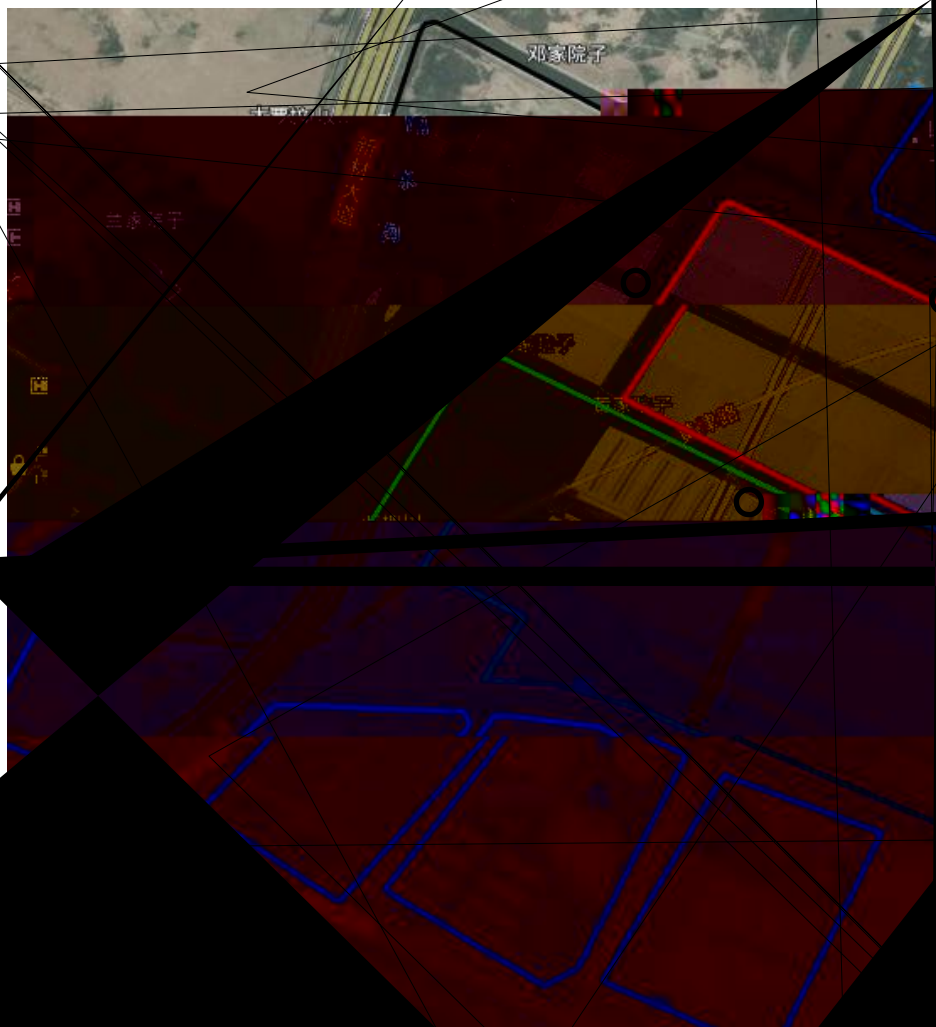

邓家院子

山家院子

王家院子

N

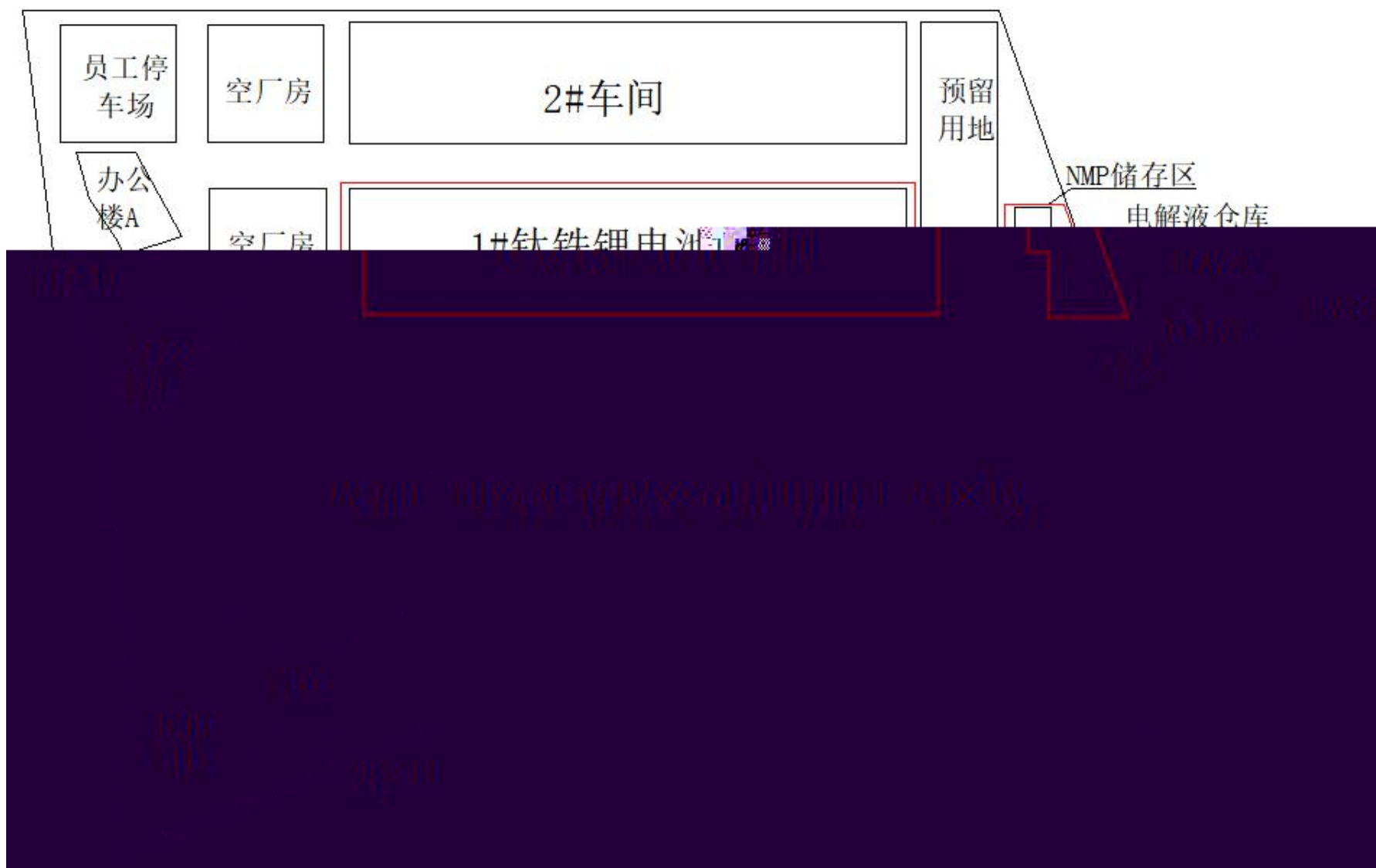



□ NMP





□ NMP

